

PG-800

SPECIFICATIONS

Dimensions 265(W) x 215(D) x 27(H) mm
 10-7/16 x 8-7/16 x 1-1/16 in
 Weight 680g / 1 lb 8 oz

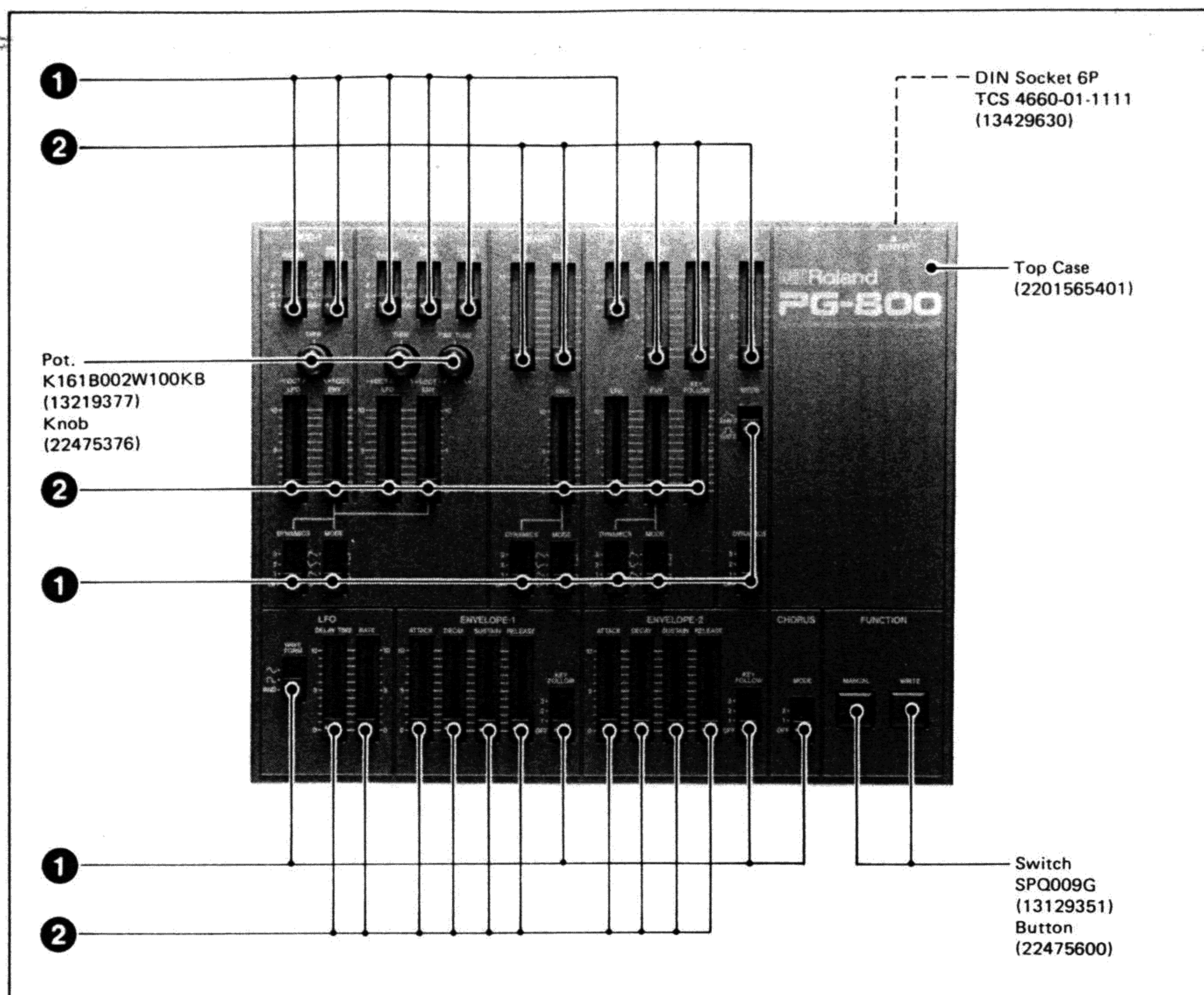

- ① Pot. EWAKF8X15B15 100KB (13379868) } Knob (22475375)
- ② Pot. EWANFEX15B15 100KB (13339453) }

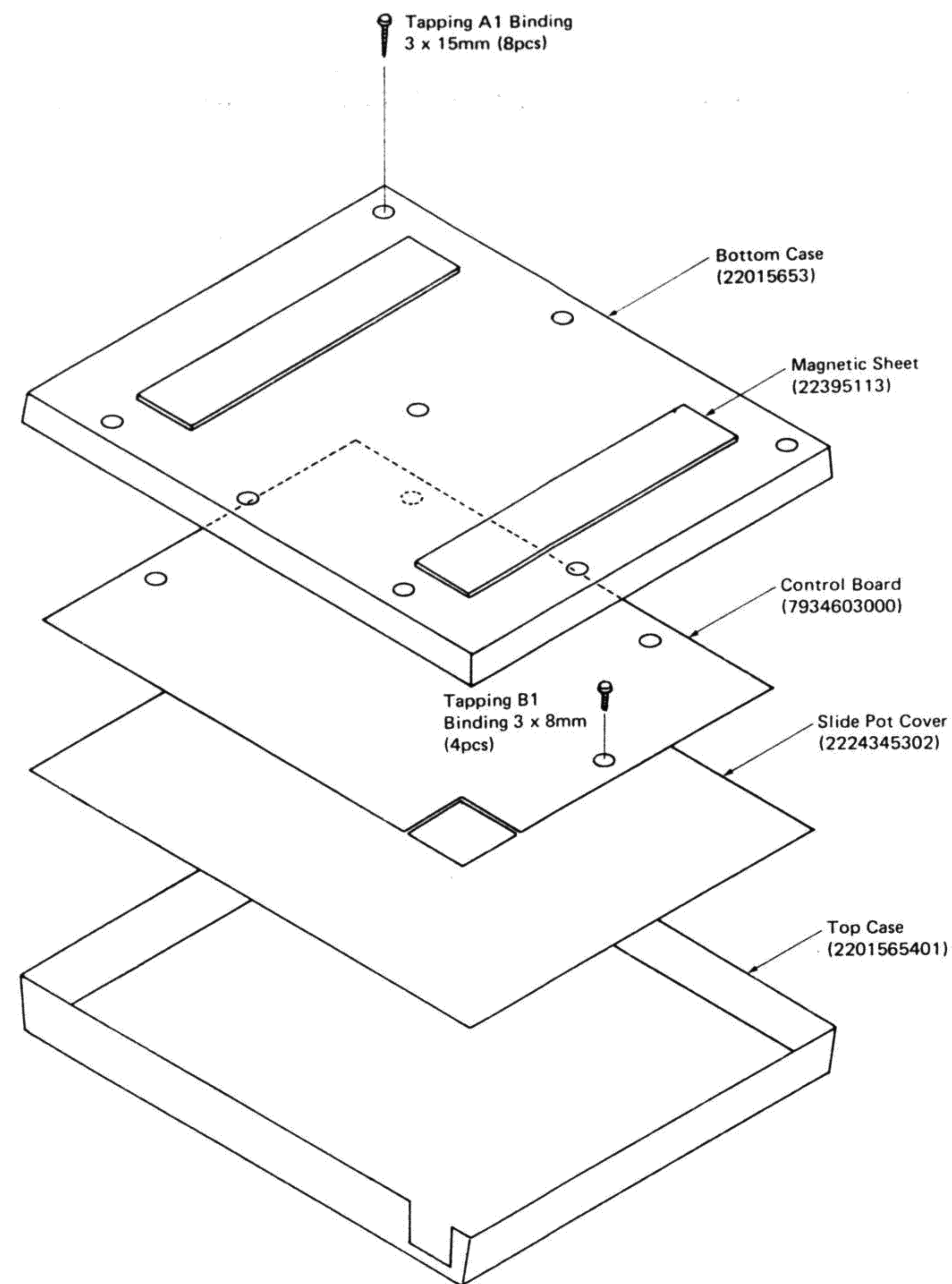

PARTS LIST (PG-800)

CASE	
2201565401	Top Case
22015653	Bottom Case

KNOB, BUTTON	
22475375	Knob slide pot
22475376	Knob rotary pot
22475600	Button push switch

SOCKET	
13429630	TCS4660-01-1111 6P DIN

PCB	
7934603000	Control Board (pcb 2292312301)

IC	
15179202	μPD8048HC-191 CPU
15129150	μPD7001C A/D converter
15159113HO	HD14051BP Single 8-CH MUX/DMUX

TRANSISTOR	
15129150	2SD880-Y
15129107	2SC945-Q
15119133	DTA114C digital
15129150	DTC114C digital

RESONATOR	
12389800	KMFC1005T1 6MHz, ceramic

POTENTIOMETER	
13219377	K161B002W-100KB rotary
13339453	EWANFEX15-B15 slide 30mm travel
13339868	EWAKF8X15-B15 slide with click 15mm travel

SWITCH	
13129351	SPQ009G

RESISTOR ARRAY	
13919310	EM-8 103J 10K x 8

EMI FILTER	
13529105	DSS31055D223S

DIODE	
15019103	1S2473
150196130Z	05Z-5.6 zener

OTHERS	
2224345301	Slider Cover
22395113	Magnetic Sheet
22013703	Carrying Case commercially available

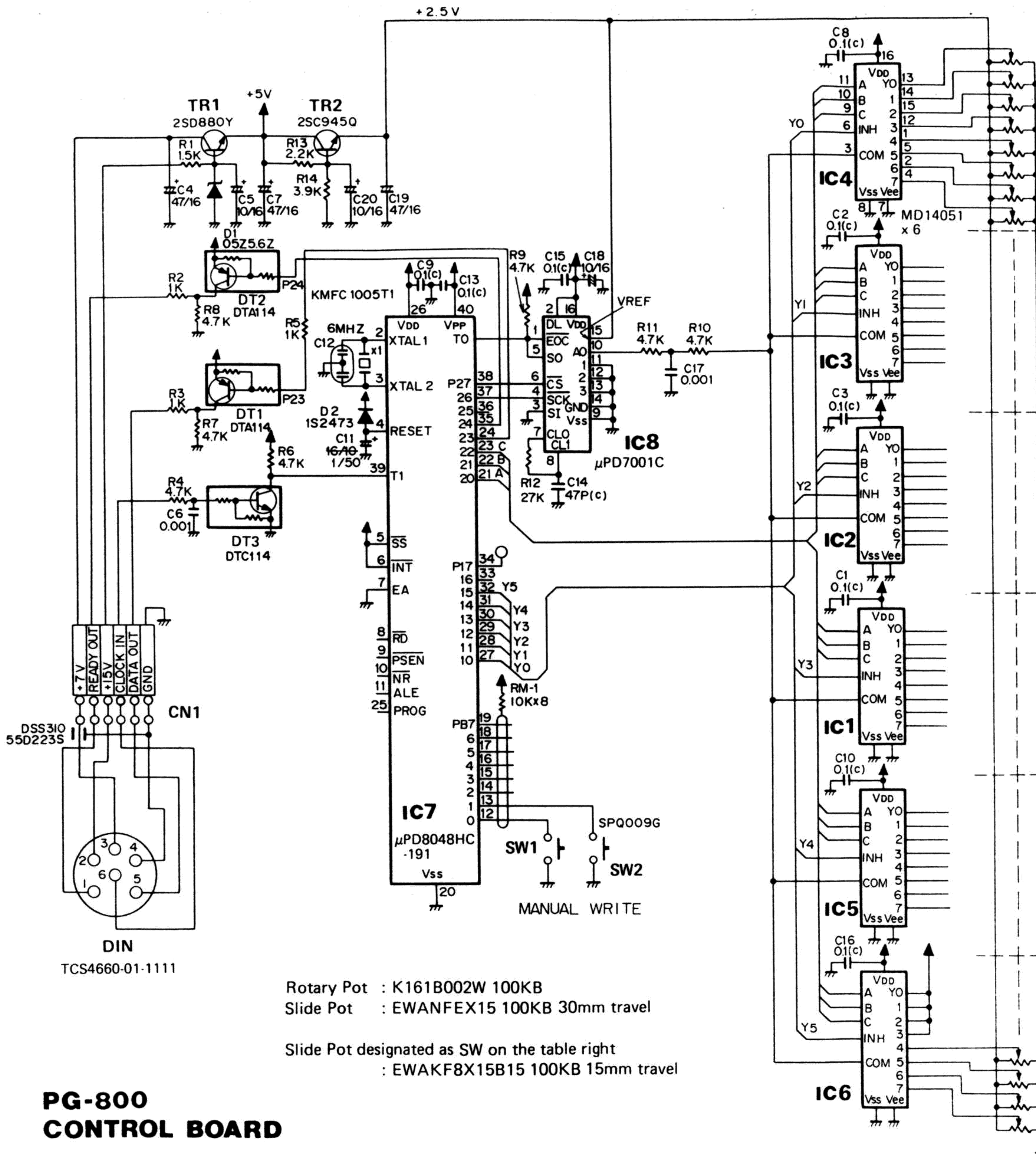

Rotary Pot : K161B002W 100KB
 Slide Pot : EWANFEX15 100KB 30mm travel
 Slide Pot designated as SW on the table right
 : EWAKF8X15B15 100KB 15mm travel

**PG-800
 CONTROL BOARD**

LEGEND	VR	FUNCTION				
		POT SLIDER	POT ROTARY	SW 4P	SW 3P	SW 2P
VCF KEYF	VR22	<input type="radio"/>				
VCF ENV	VR21	<input type="radio"/>				
VCF LFO	VR20	<input type="radio"/>				
VCA LEVEL	VR14	<input type="radio"/>				
VCF RES	VR13	<input type="radio"/>				
VCF FREQ	VR12	<input type="radio"/>				
HPF	VR11			<input type="radio"/>		
MIX DCO2	VR10	<input type="radio"/>				
DCO1 RANGE	VR1			<input type="radio"/>		
DCO1 ENV	VR16	<input type="radio"/>				
DCO2 LFO	VR17	<input type="radio"/>				
DCO2 ENV	VR18	<input type="radio"/>				
ENV1 D	VR35	<input type="radio"/>				
MIX DYNA	VR26			<input type="radio"/>		
ENV1 S	VR36	<input type="radio"/>				
ENV1 R	VR37	<input type="radio"/>				
DCO DYNA	VR24			<input type="radio"/>		
LFO WAVE	VR31				<input type="radio"/>	
DCO ENV MODE	VR25			<input type="radio"/>		
DCO1 LFO	VR15	<input type="radio"/>				
LFO DELAY	VR32	<input type="radio"/>				
ENV1 A	VR34	<input type="radio"/>				
LFO RATE	VR33	<input type="radio"/>				
ENV1 KEYF	VR38			<input type="radio"/>		
DCO2 TUNE	VR7		<input type="radio"/>			
DCO1 TUNE	VR6		<input type="radio"/>			
DCO1 WAVE	VR2			<input type="radio"/>		
DCO2 RANGE	VR3			<input type="radio"/>		
MIX DCO1	VR9	<input type="radio"/>				
DC2 WAVE	VR4			<input type="radio"/>		
DCO2 FINE	VR8		<input type="radio"/>			
DCO2 CROSS	VR5			<input type="radio"/>		
VCF ENV MODE	VR29			<input type="radio"/>		
VCF DYNA	VR28			<input type="radio"/>		
MIX ENV MODE	VR27			<input type="radio"/>		
VCA DYNA	VR30			<input type="radio"/>		
ENV2 S	VR41	<input type="radio"/>				
MIX ENV	VR19	<input type="radio"/>				
ENV2 R	VR42	<input type="radio"/>				
VCA MODE	VR23					<input type="radio"/>
undefind						
undefind						
undefind						
undefind						
ENV2 KEYF	VR43			<input type="radio"/>		
ENV2 D	VR40	<input type="radio"/>				
CHORUS	VR44				<input type="radio"/>	
ENV2 A	VR39	<input type="radio"/>				

CONTROL BOARD

7934603000

(pcb 2292312301)

